

Thomas Homes & R.V. Center Inc

Show Home #4

2022 CJS 2216 22x76
1,672 Sq. Ft – 3 Bed/2 Bath

**Includes 1 Year of Free Homeowners Insurance/ Includes Free Delivery within 300 Kilometers
Home Meets/Exceeds the New "Alberta Building Codes" for Zone 7B**

Exterior Colours:

- Vinyl Siding- Pebble
- Smart Start Windows & Doors with Faux Stone Siding Under Living Room Window
- 30 years Fiberglass Shingles: Dual Brown
- Coloured Metal Fascia: Heritage Brown

Interior Colours:

- Wall Colour: Pumice White
- Flooring: Vinyl Plank Flooring: Olympus Throughout, Except for Bedrooms/Closets
- Carpet Colour: Misty Valley in Master Bedroom, Bedroom #2 & Bedroom #3
- Cabinets: PVC V-Groove Smokewood Cabinets in Kitchen & Both Bathrooms

Added Options:

- Upgraded Appliances: S/S French Door with Bottom Freezer, S/S Ceran Cook Top, S/S Dishwasher with S/S Tub and S/S European Rangehood
- Island with Extended Eating Bar and Three Built in Storage/Pantry Cabinets
- Crown Mouldings Over Upper Kitchen Cabinets
- Decora Switch Package
- Full Ceramic Tile Backsplash in Kitchen in Quayside Brown
- Set of Five Pot Lights in Kitchen with 2 Pendant Lights Above Island-Upgraded LED Light Package
- Upgraded Countertop in Spring Carnival with Soft Close Hinges & Drawers, Upgraded Handles
- Cabinet Above Washer/Dryer in Utility Room
- 5' Walk In Shower with Glass Door in Ensuite
- Two Storm Doors-Front & Rear Entrance with Heavy Front Door Latch Kit on Front Entrance
- 9 Lite Insert for Both Entry Doors
- 50 USG Conv Gas Hot Water Tank with Insulated Water Lines in HWT Cavity
- Utility Passage Door-Open Above (No Grill)
- A/C Ready Split system-30 Amp Breaker, Coil Cabinet in Furnace, 2 Speed Furnace Motor & Junction Box
- HRV System with upgraded Casement/Awning Windows Throughout
- Two 22"x30" Added Windows in Ensuite & Main Bathroom
- Transom Windows Above Four Windows

Thomas Homes & R.V. Center

Box 7020 9900-78ST Peace River, AB

www.thomashomesandriv.com PH# 780-624-2720

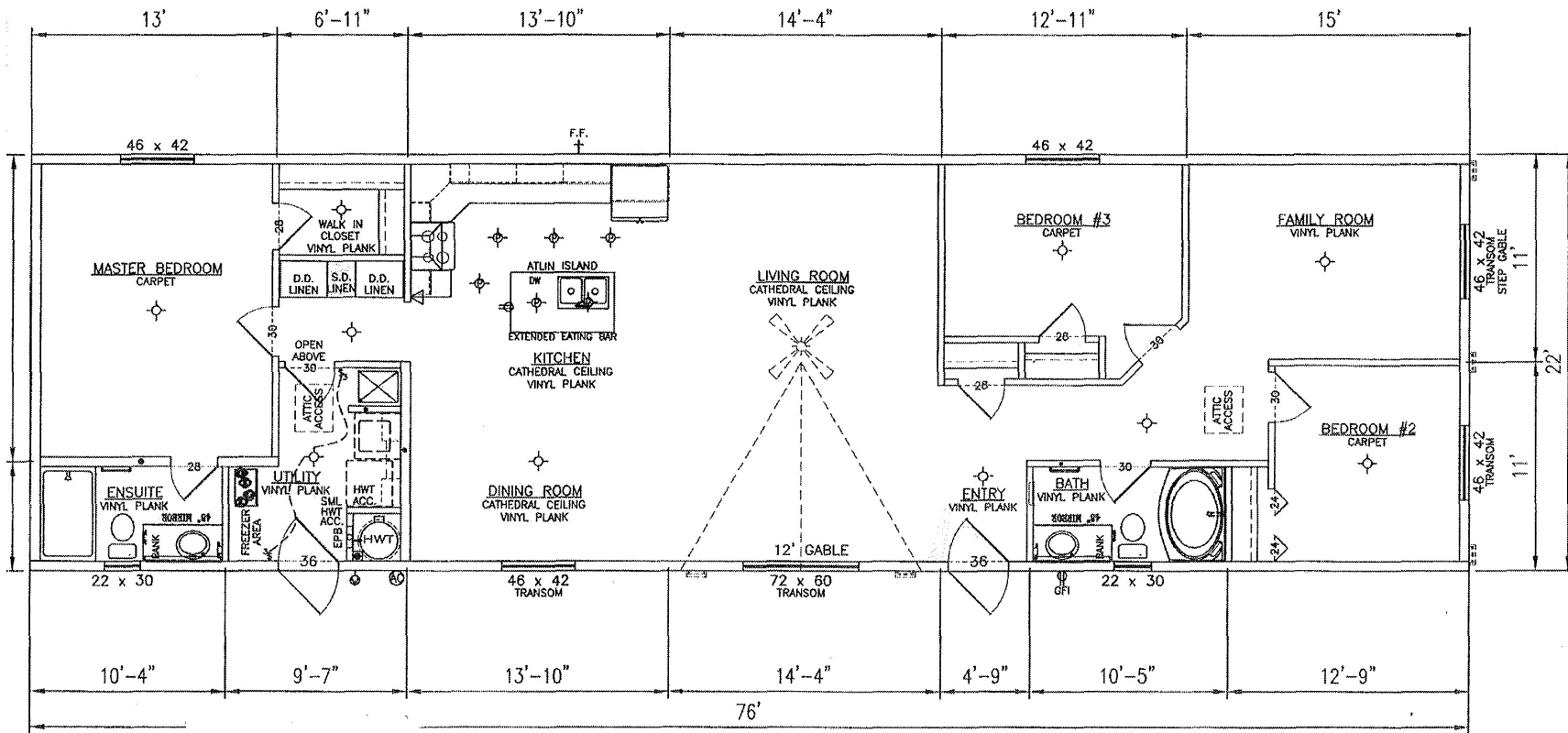

Show Home #4 CJS 2216

2022 22x76 1672 Sq. Ft 3 Bed/2 Bath

